

ULTRAFLOW®

Cooling flow sensor

Ultrasonic flow sensor

Compact design

Static meter with no moving parts

Large dynamic range

No wear

Exceptionally accurate

Longevity

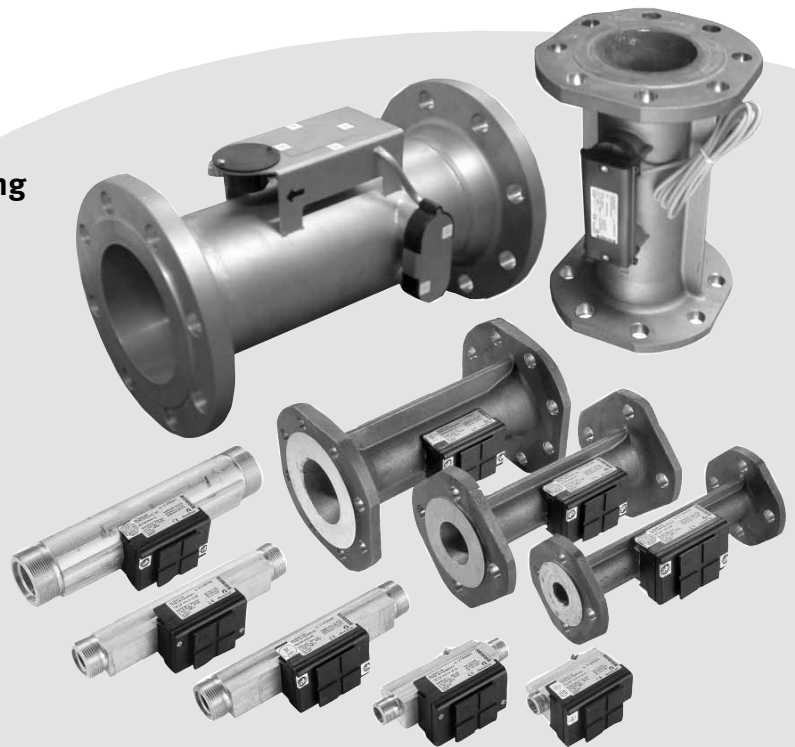

Application

ULTRAFLOW® type 65-T is a static flow sensor based on the ultrasonic measuring principle. The prime area of application is as a volume flow sensor for use with thermal heat meters such as MULTICAL® and MAXICAL. ULTRAFLOW® type 65-T has been designed for use in cooling installations where water is used as the energy-bearing medium.

ULTRAFLOW® employs micro-processor technology and ultrasonic measuring techniques. All circuits for calculating and measuring are collected on a single board, providing compact and rational design in addition to an exceptionally high level of measuring accuracy and reliability.

The flow is measured using bidirectional ultrasonic technique based on the transit time method, with proven long-term stability and accuracy. Two ultrasonic transducers are used to send the sound signal both against and with the flow direction.

The ultrasonic signal travelling with the flow direction reaches the opposite transducer first. The time difference between the two signals can be converted to a flow velocity and thus a volume.

A multiplug, placed beneath the seal, is used during communication and calibration.

A three-wire pulse cable is used to connect ULTRAFLOW® to the calculator. This cable is used to supply the flow sensor from the calculator and also to send the signal to the calculator. The signal corresponds to the flow, or more correctly, a number of pulses proportional to the water volume flowing through the meter is transmitted.

If required a PULSE TRANSMITTER can be used to supply ULTRAFLOW®, e.g. if the distance between MULTICAL® and ULTRAFLOW® is 10 m or more.

The PULSE TRANSMITTER has a built-in supply and a galvanically separated pulse outlet.



Kamstrup

Kamstrup A/S
Industrivej 28, Stilling
DK-8660 Skanderborg
TEL: +45 89 93 10 00
FAX: +45 89 93 10 01
info@kamstrup.com
www.kamstrup.com

Approvals

CE-marking

ULTRAFLOW® type 65-T is marked in accordance with:

EMC-directive	89/336/EEC
LV-directive	73/23/EEC (together with the PULSE TRANSMITTER)

PE-directive

97/23/EC
(DN50...DN100 category I,
DN150...DN250 category II)

Technical data

Mechanical data

Metrological class	2 and 3
Environmental class	Complies with DS/EN 1434 class C
Ambient temperature	0...55°C
Protection class	
Flow sensor	IP65
PULSE TRANSMITTER	IP54
Temperature of medium	2...50°C
Storage temp. drained meter	- 25...70°C, 60°C with fitted/supplied battery
Pressure stage	PN16, PN25 flange
Time constant	6 s, fast response meter

Electrical data

Supply voltage	3.6 V ± 10%
Battery (PULSE TRANSMITTER)	3.65 VDC, D-Cell lithium
Replacement interval	6 years @ $t_{BAT} < 35^{\circ}\text{C}$
Power supply (PULSE TRANSMITTER)	230 VAC + 15/- 30%, 48...52 Hz 24 VAC ± 30%
Back-up supply	Integral super-cap eliminates operational disturbances due to short-term power-cuts.
Cable length, flow sensor	Max. 10 m
Cable length (PULSE TRANSMITTER)	Depends on calculator
EMC data	Complies with DS/EN 1434 class C

Flow data

Nom. flow q_p [m³/h]	Nom. diameter	Meter factor ¹⁾ [pulses/l]	Dynamic range $q_i:q_p$	$q_s:q_p$	Flow @125 Hz ²⁾ [m³/h]	Δp [bar]	Min. cut off [l/h]
0.6	DN15 & DN20	300	1:100	2:1	1.5	0.04	2
1.5	DN15 & DN20	100	1:100	2:1	4.5	0.23	3
3	DN20	50	1:100	2:1	9	0.05	6
3.5	DN25	50	1:100	2:1	9	0.07	7
6	DN25	25	1:100	2:1	18	0.19	12
10	DN40	15	1:100	2:1	30	0.06	20
15	DN50	10	1:100	2:1	45	0.14	30
25	DN65	6	1:100	2:1	75	0.06	50
40	DN80	5	1:100	2:1	90	0.15	80
60	DN100	2.5	1:100	2:1	180	0.01	120
100	DN100	1.5	1:100	2:1	300	0.03	200
150	DN150	1	1:100	2:1	450	0.02	300
250	DN150	0.6	1:100	2:1	750	0.055	500
400	DN150	0.4	1:100	2:1	1125	0.038	800
400	DN200	0.4	1:100	2:1	1125	0.01	800
400	DN250	0.4	1:100	2:1	1125	0.01	800
600	DN200	0.25	1:100	2:1	1800	0.022	1200
600	DN250	0.25	1:100	2:1	1800	0.022	1200
1000	DN250	0.25	1:100	1.8:1	1800	0.015	2000

¹⁾ The meter factor can be seen on the label on the side of the meter.

²⁾ Saturation flow. Max. pulse frequency 128 Hz is maintained at higher flow rates.

Materials

Wetted parts

ULTRAFLOW[®], q_p 0.6 and 1.5 m³/h	
Housing	Enkotal (alpha brass)
Transducers	AISI 316 (W.no. 1.4401)
Gaskets	EPDM
Reflectors	PES 30% GF and AISI 304 (W.no. 1.4301)
Measuring pipe	PES 30% GF

ULTRAFLOW[®], q_p 3 to 100 m³/h

Housing, gland	Enkotal (alpha brass)
Housing, flange	RG5204 (red brass)
Transducers	AISI 316 (W.no. 1.4401)
Gaskets	EPDM
Measuring pipe	PES 30% GF
Reflectors	AISI 304 (W.no. 1.4301)

ULTRAFLOW[®], q_p 150 to 1000 m³/h

Housing	AISI 304 (W.no. 1.4301)
Transducers	AISI 316/Enkotal
Gaskets	EPDM
Measuring pipe	Integral part of the housing

Electronic housing

Base	PBT 30% GF
Lid	PC 10% GF

Connection cable q_p 0.6 to 100 m³/h

Silicone cable (3 x 0.5[□])

Type summary

Nom. flow q _p [m ³ /h]	Size			
0.6	G ³ / ₄ x 110 mm	G1 x 130 mm		
1.5	G ³ / ₄ x 110 mm	G ³ / ₄ x 165 mm	G1 x 130 mm	G1 x 190 mm
3	G1 x 190 mm	DN20 x 190 mm		
3.5	G5/4 x 260 mm	DN25 x 260 mm		
6	G5/4 x 260 mm	DN25 x 260 mm		
10	G2 x 300 mm	DN40 x 300 mm		
15	DN50 x 270 mm			
25	DN65 x 300 mm			
40	DN80 x 300 mm			
60	DN100 x 360 mm			
100	DN100 x 360 mm			
150	DN150 x 500 mm			
250	DN150 x 500 mm			
400	DN150 x 500 mm	DN200 x 500 mm	DN250 x 600 mm	
600	DN200 x 500 mm	DN250 x 600 mm		
1000	DN250 x 600 mm			

Gland ISO 228-1

Flange EN 1092-1/-3, PN25

Dimension sketches

ULTRAFLOW® type 65-T, G³/₄ and G1

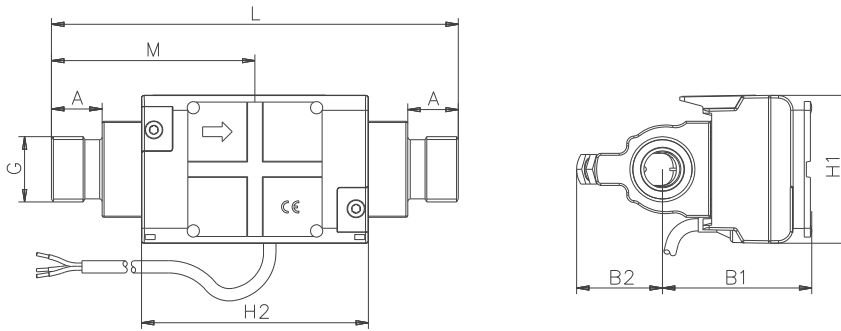

Gland ISO 228-1

Thread	L	M	H2	A	B1	B2	H1	App. weight [kg]
G ³ / ₄	110	L/2	92	10.5	61	35	60	0.8
G1	130	L/2	92	20.5	61	35	60	0.9
G ³ / ₄	165	L/2	92	20.5	61	35	60	1.2
G1 (q _p 1.5)	190	L/2	92	20.5	61	35	60	1.4
G1 (q _p 3.0)	190	L/2	92	20.5	60	36	60	1.3

ULTRAFLOW® type 65-T, G5/4 and G2

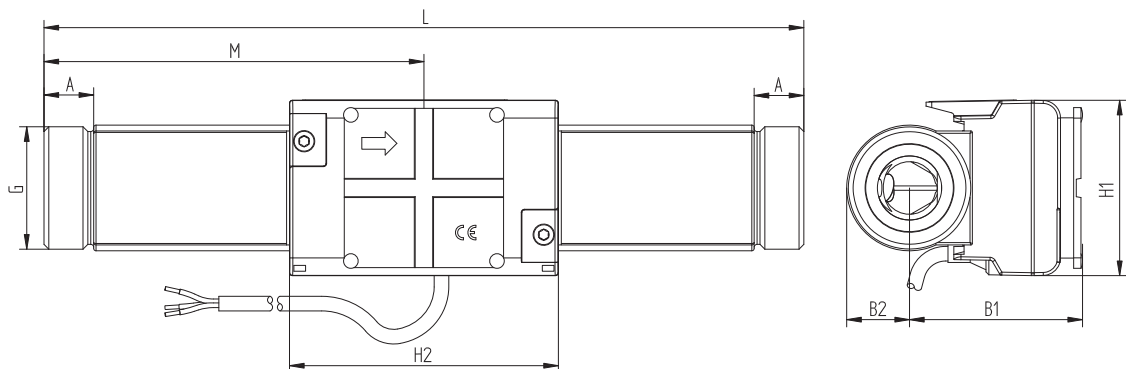

Gland ISO 228-1

Thread	L	M	H2	A	B1	B2	H1	App. weight [kg]
G5/4	260	L/2	92	17	60	22	60	2.3
G2	300	L/2	92	21	68	31	60	4.5

ULTRAFLOW® type 65-T, DN20 to DN50

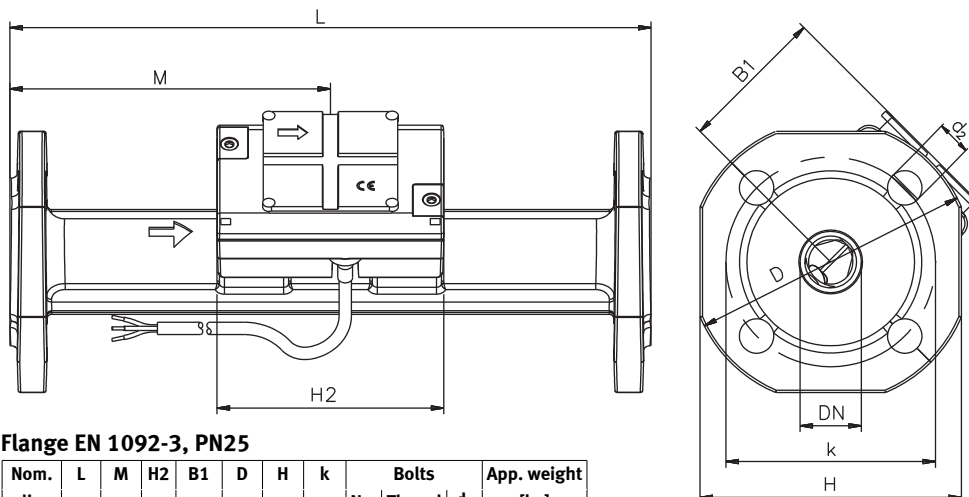

Flange EN 1092-3, PN25

Nom. dia.	L	M	H2	B1	D	H	k	Bolts			App. weight [kg]
								No.	Thread	d ₂	
DN20	190	L/2	92	60	105	95	75	4	M12	14	2.9
DN25	260	L/2	92	60	115	106	85	4	M12	14	5.0
DN40	300	L/2	92	<D/2	150	136	110	4	M16	18	8.3
DN50	270	155	92	<D/2	165	145	125	4	M16	18	10.1

Dimension sketches (continued)

ULTRAFLOW® type 65-T, DN65 and DN80

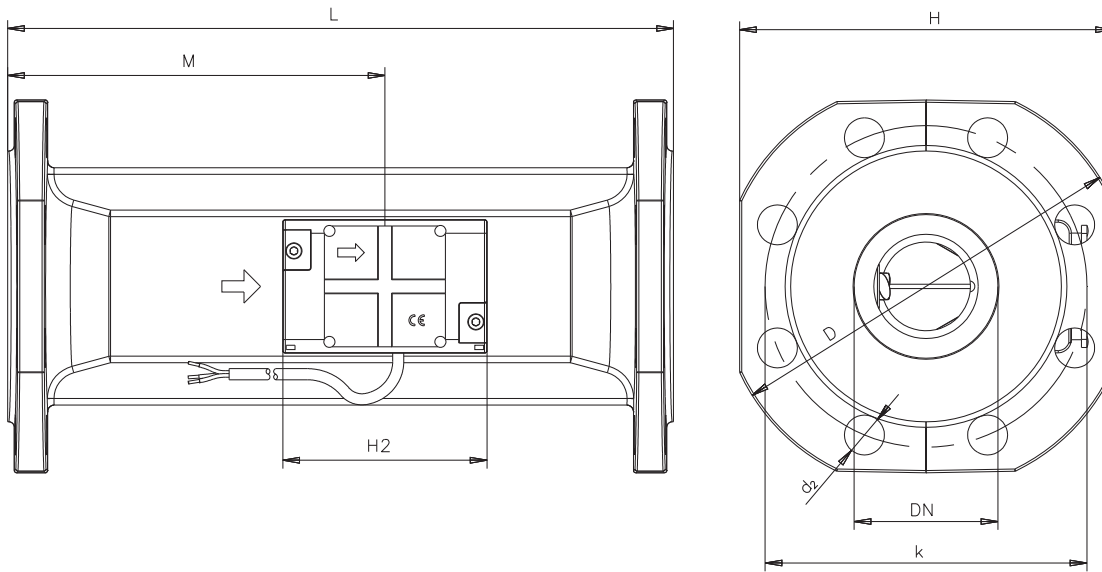

Flange EN 1092-3, PN25

Nom. dia.	L	M	H2	B1	D	H	k	Bolts			App. weight [kg]
								No.	Thread	d ₂	
DN65	300	170	92	<H/2	185	168	145	8	M16	18	13.2
DN80	300	170	92	<H/2	200	184	160	8	M16	18	16.8

ULTRAFLOW® type 65-T, DN100

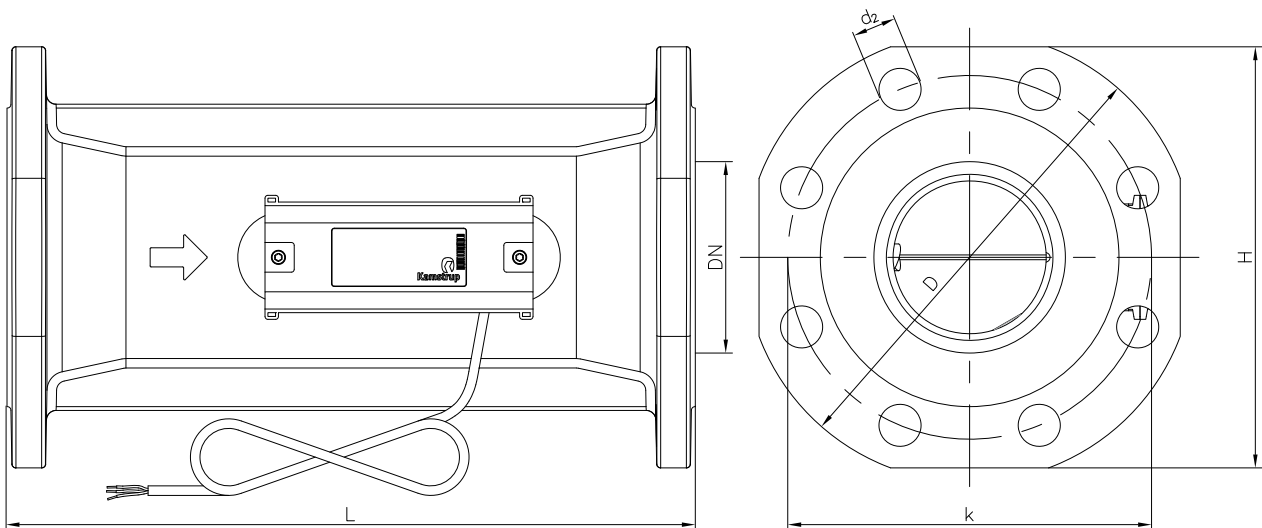

Flange EN 1092-3, PN25

Nom. dia.	L	D	H	k	Bolts			App. weight. [kg]
					No.	Thread	d ₂	
DN100	360	235	220	190	8	M20	22	25.6

Dimension sketches (continued)

ULTRAFLOW® type 65-T, DN150, DN200 and DN250

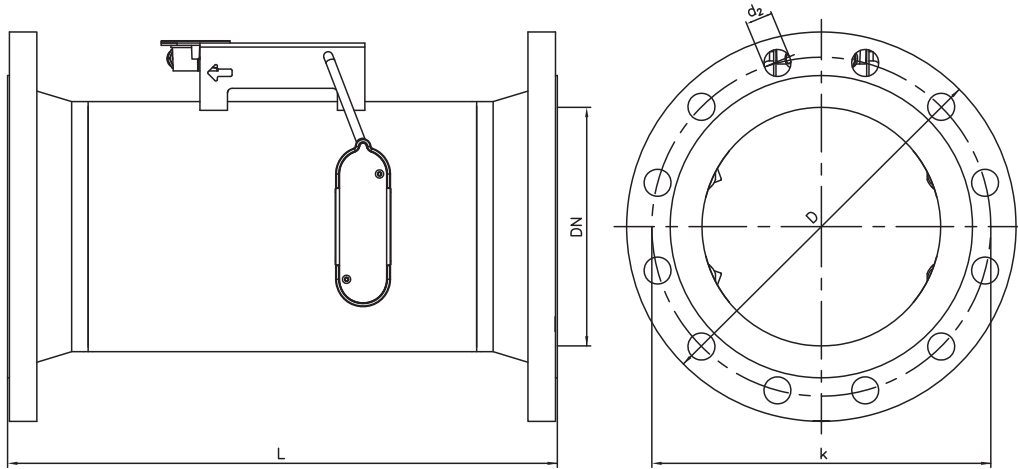

Flange EN 1092-1, PN25

Nom. dia.	L	D	k	Bolts			App. weight [kg]
				No.	Thread	d ₂	
DN150	500	300	250	8	M24	26	37
DN150 (q _p 400 m ³ /h)	500	300	250	8	M24	26	32
DN200	500	360	310	12	M24	26	47
DN250	600	425	370	12	M27	29.5	68
DN250 (q _p 1000 m ³ /h)	600	425	370	12	M27	29.5	65

PULSE TRANSMITTER

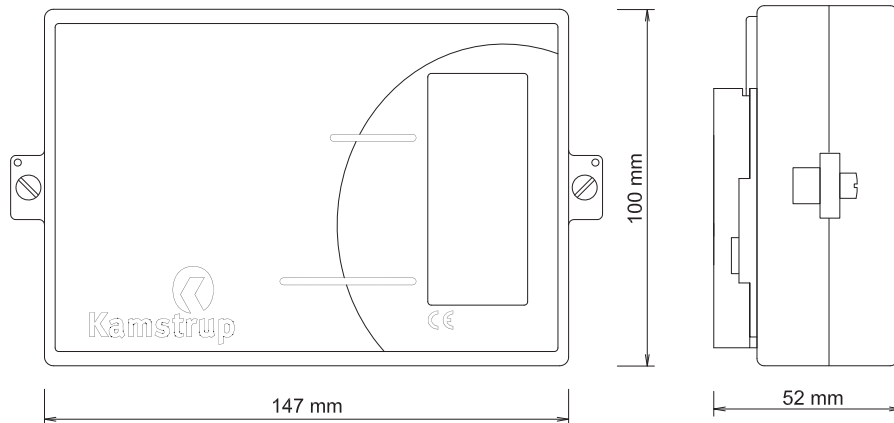

Pressure loss

Graph	q _p [m ³ /h]	Nom. diameter	k _v ³⁾	Q @ 0.25 bar [m ³ /h]
A	0.6 & 1.5	DN15 & DN20	3	1.5
B	3 & 3.5 & 6	DN20 & DN25	13.5	6.8
C	10 & 15	DN40 & DN50	43	21.5
D	25 & 40	DN65 & DN80	103	52
E	60 & 100	DN100	600	300
F	150 & 250	DN150	1060	530
G	400	DN150	2050	1025
H	400 & 600	DN200 & DN250	4040	2020
j	1000	DN250	8160	4080

³⁾ $q = k_v \times \sqrt{\Delta p}$

Pressure loss graphs

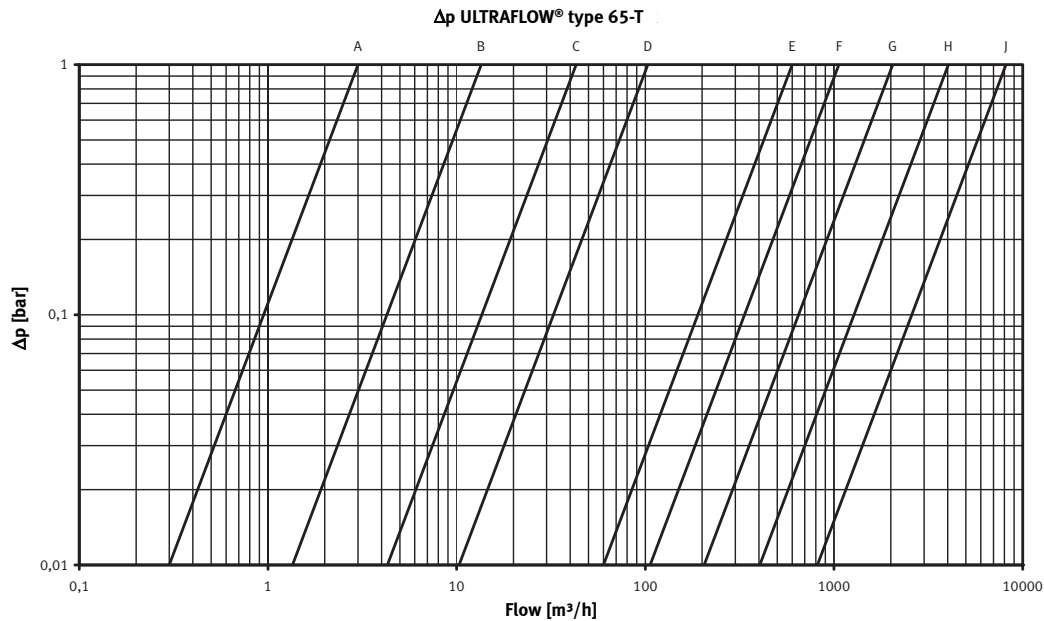

Installation

ULTRAFLOW® ≤ DN100

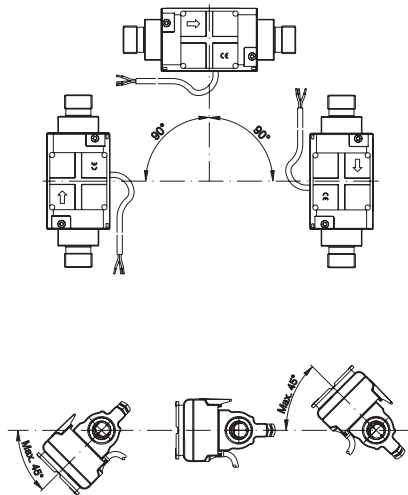

ULTRAFLOW® may be installed horizontally, vertically or at an angle.

IMPORTANT!

With ULTRAFLOW® ≤ DN100 (100 m³/h), the electronics/plastic case must be placed to the side (with horizontal installation).

ULTRAFLOW® may be turned up to ± 45° in relation to the pipe axis.

Straight inlet (UF 65-T)

ULTRAFLOW® requires neither straight inlet nor outlet to meet the Measuring Instruments Directive (MID) 2004/22/EC, OIML R75:2002 and EN 1434:2007. Only in case of heavy flow disturbances before the meter will a straight inlet section be necessary. We recommend to follow the guidelines in CEN CR 13582.

ULTRAFLOW® ≥ DN150

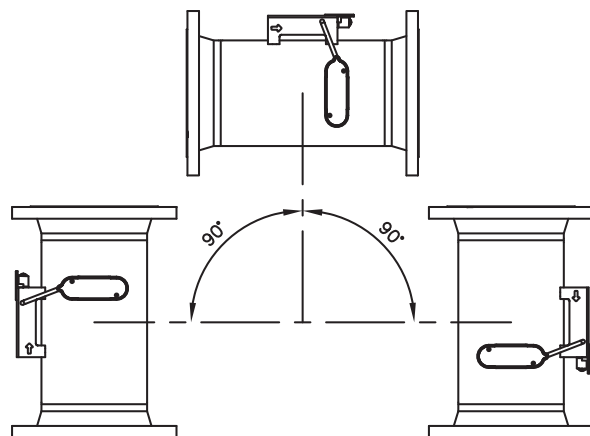

ULTRAFLOW® may be installed horizontally, vertically or at an angle.

IMPORTANT!

With ULTRAFLOW® ≥ DN150 (150 m³/h), the electronics/plastic case must be placed upwards (with horizontal installation).

ULTRAFLOW® may be turned up to ± 45° in relation to the pipe axis.

Working Pressure

In order to prevent cavitation the working pressure at ULTRAFLOW® must be min. 1.5 bar at q_p and min. 2.5 bar at q_s (4.5 bar for DN80). This applies to temperatures up to approx. 80°C.

ULTRAFLOW® must not be exposed to lower pressure than the ambient pressure (vacuum).

Examples of installation

Gland meter with MULTICAL®/PULSE TRANSMITTER fitted directly on ULTRAFLOW®.

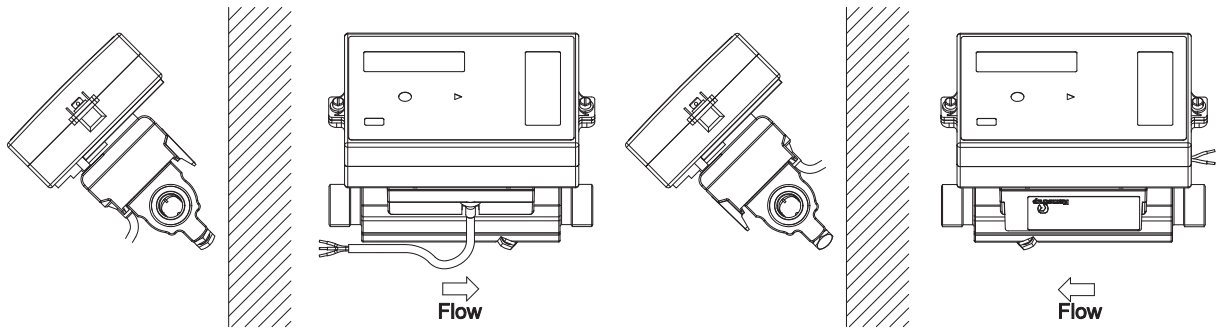

Glands and short direct sensor fitted in ULTRAFLOW® (G $\frac{3}{4}$ (R $\frac{1}{2}$) and G1 (R $\frac{3}{4}$) only).

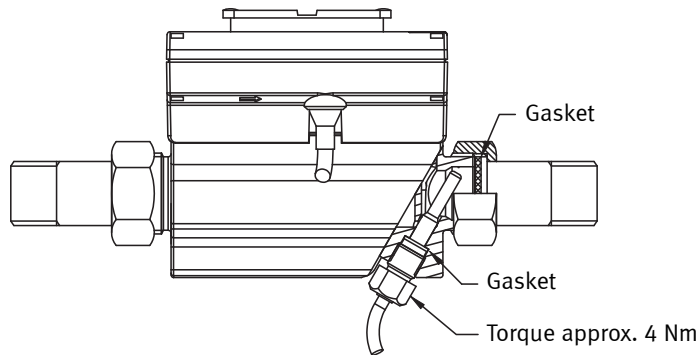

Flange meter with MULTICAL®/PULSE TRANSMITTER fitted directly on ULTRAFLOW®.

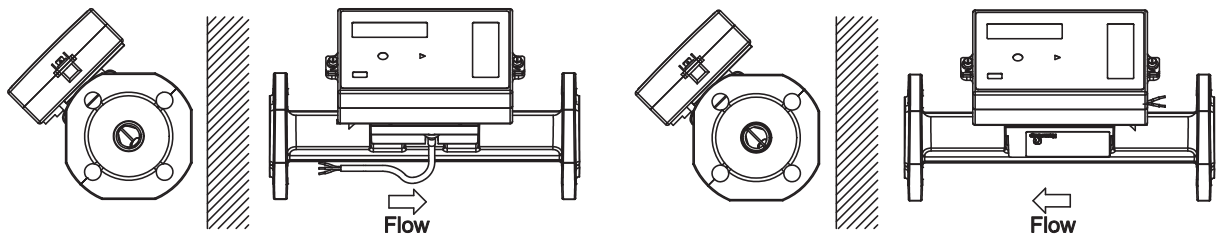

NB: For meters \geq DN100 MULTICAL® or the PULSE TRANSMITTER cannot be fitted directly on the flow part.

Electrical connection

Connecting MULTICAL®/MAXICAL III & ULTRAFLOW®

ULTRAFLOW®	->	MULTICAL®, MAXICAL III
Blue (ground)/11A	->	11
Red (supply)/9A	->	9
Yellow (signal)/10A	->	10

ULTRAFLOW®	->	PULSE TRANSMITTER		->	MULTICAL®
		In	Out		
Blue (ground)/11A	->	11	11A	->	11
Red (supply)/9A	->	9	9A	->	9
Yellow (signal)/10A	->	10	10A	->	10

Connecting via pulse transmitter

3.65 VDC supply ⁴⁾	->	PULSE TRANSMITTER
Red (+)	->	60
Black (-)	->	61

⁴⁾ From battery or supply module.

ULTRAFLOW®	->	PULSE TRANSMITTER		->	MAXICAL III
		In	Out		
Blue (ground)/11A	->	11	11A	->	11
Red (supply)/9A	->	9			
Yellow (signal)/10A	->	10	10A	->	10

If long signal cables are used, please consider the installation carefully. There must be at least 25 cm between the signal cable and all other cables due to EMC.

Example of connecting ULTRAFLOW® and MULTICAL®

ULTRAFLOW® type 65-T, $q_p \leq 100 \text{ m}^3/\text{h}$

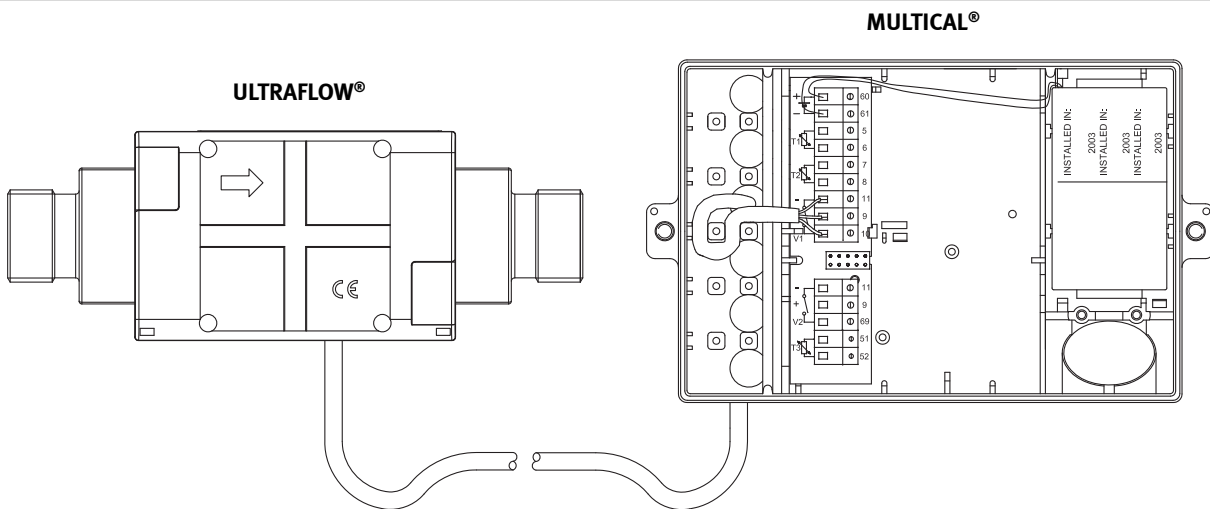

ULTRAFLOW® type 65-T with terminal, $q_p \geq 150 \text{ m}^3/\text{h}$

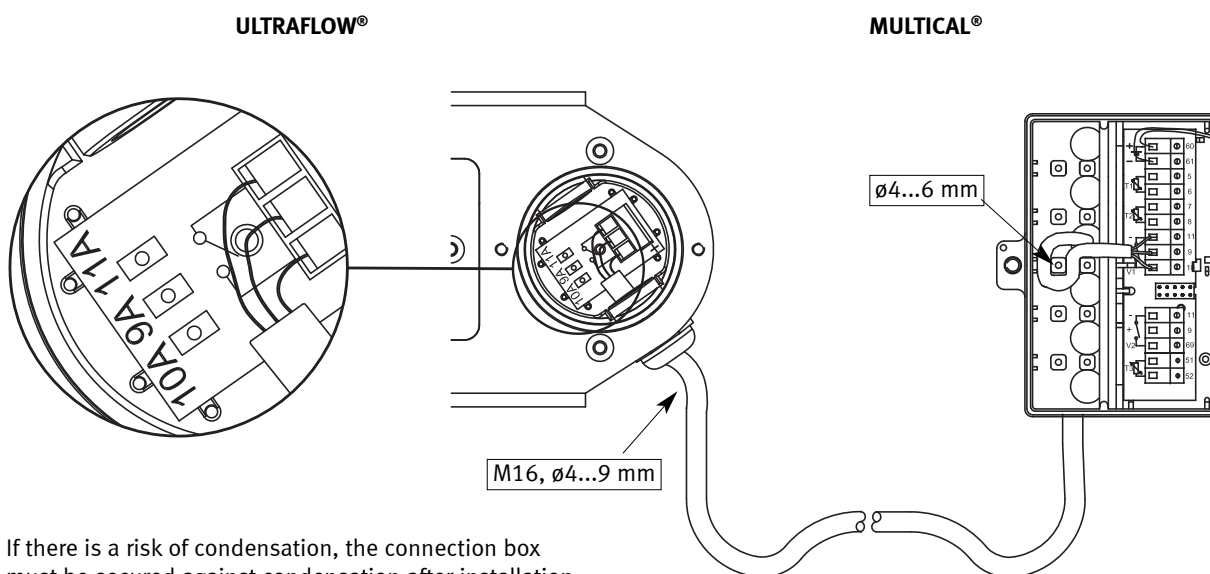

If there is a risk of condensation, the connection box must be secured against condensation after installation.

Order specification

The list below shows type numbers for ULTRAFLOW® type 65-T.

Type number ⁵⁾	q _p [m ³ /h]	q _i [m ³ /h]	q _s [m ³ /h]	Connection	Length [mm]	Meter factor [pulses/l]	CCC
65-T-CAAA-XXX	0.6	0.006	1.2	G ³ / ₄ B (R ¹ / ₂)	110	300	116 or 184
65-T-CAAD-XXX	0.6	0.006	1.2	G1B (R ³ / ₄)	130	300	116 or 184
65-T-CDAA-XXX	1.5	0.015	3.0	G ³ / ₄ B (R ¹ / ₂)	110	100	119 or 107
65-T-CDAC-XXX	1.5	0.015	3.0	G ³ / ₄ B (R ¹ / ₂)	165	100	119 or 107
65-T-CDAD-XXX	1.5	0.015	3.0	G1B (R ³ / ₄)	130	100	119 or 107
65-T-CDAF-XXX	1.5	0.015	3.0	G1B (R ³ / ₄)	190	100	119 or 107
65-T-CFAF-XXX	3.0	0.03	6.0	G1B (R ³ / ₄)	190	50	136
65-T-CFBA-XXX	3.0	0.03	6.0	DN20	190	50	136
65-T-CGAG-XXX	3.5	0.035	7.0	G5/4B (R1)	260	50	151 or 136
65-T-CGBB-XXX	3.5	0.035	7.0	DN25	260	50	151 or 136
65-T-CHAG-XXX	6.0	0.06	12	G5/4B (R1)	260	25	137 or 138
65-T-CHBB-XXX	6.0	0.06	12	DN25	260	25	137 or 138
65-T-CJAJ-XXX	10	0.1	20	G2B (R1 ¹ / ₂)	300	15	178 or 183
65-T-CJBD-XXX	10	0.1	20	DN40	300	15	178 or 183
65-T-CKBE-XXX	15	0.15	30	DN50	270	10	120 or 185
65-T-CLBG-XXX	25	0.25	50	DN65	300	6	179
65-T-CMBH-XXX	40	0.4	80	DN80	300	5	158 or 186
65-T-FACL-XXX	60	0.6	120	DN100	360	2.5	170 or 187
65-T-FBCL-XXX	100	1.0	200	DN100	360	1.5	180 or 188
65-T-FCCN-XXX	150	1.5	300	DN150	500	1	147 or 189
65-T-FDCN-XXX	250	2.5	500	DN150	500	0.6	181
65-T-FECN-XXX	400	4.0	800	DN150	500	0.4	171 or 191
65-T-FECP-XXX	400	4.0	800	DN200	500	0.4	171 or 191
65-T-FECP-XXX	400	4.0	800	DN250	600	0.4	171 or 191
65-T-FFCP-XXX	600	6.0	1200	DN200	500	0.25	172 or 192
65-T-FFCP-XXX	600	6.0	1200	DN250	600	0.25	172 or 192
65-T-F1CR-XXX	1000	10.0	1800	DN250	600	0.25	172 or 192

⁵⁾ XXX-code pertaining to final assembly, approvals etc. is determined by Kamstrup A/S.
Some variants may not be included in national approvals.

ULTRAFLOW® type 65-T ≤ DN100 is as standard supplied with 2.5 m cable, but can also be supplied with 5 or 10 m cable.

ULTRAFLOW® ≥ DN150 is supplied without cable. A 5 m or 10 m cable can be ordered and delivered, separately.

PULSE TRANSMITTER - type No. 66-99-603

The PULSE TRANSMITTER is supplied with built in supply for ULTRAFLOW®. Battery, 24 VAC and 230 VAC supply are available. Please state the required supply type when ordering.

Accessories

Glands including gaskets (PN16)

Size	Type No.	2 pcs.
DN15, (R $\frac{1}{2}$ x G $\frac{3}{4}$)		65-61-321
DN20, (R $\frac{3}{4}$ x G1)		65-61-322
DN25, (R1 x G $\frac{5}{4}$)	65-61-313	
DN40, (R1 $\frac{1}{2}$ x G2)	65-61-315	

Gaskets for glands

Size	Type No.
G $\frac{3}{4}$	2210-061
G1	2210-062
G $\frac{5}{4}$	2210-063
G2	2210-065

Gaskets for flange meters

Size	Type No.
DN20	2210-147
DN25	2210-133
DN40	2210-132
DN50	2210-099
DN65	2210-141
DN80	2210-140
DN100	1150-142
DN150	1150-140
DN200	1150-139
DN250	1150-141

Authorized distributor

Please contact Kamstrup A/S for information about your nearest distributor.