

MULTICAL® 801

Precise measuring of heat and cooling up to 30,000 m³/h

Remote reading with four communication channels

4 analogue outputs

Two plug-in modules simultaneously:
– GSM, M-Bus, RadioRouter, LonWorks
pulse inputs for electricity and water meters

Data logger with latest 460 days, 36 months and 15 years as well as programmable data logger

Complies with EN 1434:2007 Class C and MID M1, E1 and E2



DK-0200-MI004-009

MID-2004/22/EC

CE M08 0200

IP67

Application

MULTICAL® 801 is a robust and rugged calculator. It is ideal for buildings and industries using extra communication possibilities, programmable functions and a wide range of other modules.

MULTICAL® 801 is used for measurement of both heat and cooling in all water based plants with flow temperatures from 2°C to 180°C and with all flow meter sizes between qp 0.6 m³/h and qp 30,000 m³/h.

The meter is simple to install, read and verify. Furthermore, MULTICAL® 801 contributes to keeping the annual operating costs at a minimum with its unique combination of high measuring accuracy and long life-time.

If MULTICAL® 801 is connected to flow meters installed in both flow and return pipes, the meter can monitor leaks and burst in the heating/cooling system. Furthermore, leakages in the tap water system can be monitored by means of pulses if a water meter is connected.

MULTICAL® 801 receives volume pulses from the connected flow meters and calculates the energy for every predetermined water volume. The energy calculation includes temperature measurements in flow and return as well as correction for density and heat content according to EN 1434.

MULTICAL® 801 can be supplied by 230 VAC or 24 VAC.

MULTICAL® 801 can be extended by two independent modules in the form of GSM/GPRS, M-Bus, RadioRouter and LonWorks. The modules also include two extra pulse inputs for connection of water and electricity meters. The modules make remote reading of the meter possible.

MULTICAL® 801 fulfils the IP67 requirements to very rugged design and robust functionality. The IP67 seal guarantees that the meter is resistant to dust, humidity and water.

Pulse outputs, valve control, battery backup and many other features are standard functions in MULTICAL® 801.



Kamstrup

Kamstrup A/S
Industrivej 28, Stilling
DK-8660 Skanderborg
TEL: +45 89 93 10 00
FAX: +45 89 93 10 01
info@kamstrup.com
www.kamstrup.com

Calculator functions

Energy calculation

MULTICAL® 801 calculates energy based on the formula in EN 1434-1:2004, in which the international temperature scale from 1990 (ITS-90) and the pressure definition of 16 bar is used.

The energy calculation can in a simplified way be expressed as:

$$\text{Energy} = V \times \Delta\Theta \times k$$

V is the supplied water volume

$\Delta\Theta$ is the temperature difference measured

k is the thermal coefficient of water

The calculator always calculates energy in [Wh], and then it is converted into the selected measuring unit.

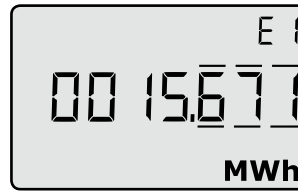

E [Wh] =	$V \times \Delta\Theta \times k \times 1000$
E [kWh] =	$E [\text{Wh}] / 1000$
E [MWh] =	$E [\text{Wh}] / 1000000$
E [GJ] =	$E [\text{Wh}] / 277780$
E [Gcal] =	$E [\text{Wh}] / 1163100$

Application types

MULTICAL® 801 operates with 9 different energy formulas, E1...E9, that are all calculated in parallel in connection with each integration no matter how the meter is configured.

The energy types E1 to E9 are calculated as follows:

$$E1 = V1(T1 - T2) \quad \text{Heat energy (V1 in flow or return)}$$

$$E2 = V2(T1 - T2) \quad \text{Heat energy (V2 in return)}$$

$$E3 = V1(T2 - T1) \quad \text{Cooling energy (V1 in flow or return)}$$

$$E4 = V1(T1 - T3) \quad \text{Forward energy}$$

$$E5 = V2(T2 - T3) \quad \text{Return energy or tapping from return}$$

$$E6 = V2(T3 - T4) \quad \text{Tap water energy, separate}$$

$$E7 = V2(T1 - T3) \quad \text{Tap water energy, flow pipe}$$

$$E8 = m^3 \times T1 \quad \text{(Flow pipe)}$$

$$E9 = m^3 \times T2 \quad \text{(Return pipe)}$$

This renders MULTICAL® 801 capable of calculating the heat and cooling energy of most applications, both closed and open systems.

All energy types are data logged and can be displayed independent of configuration.

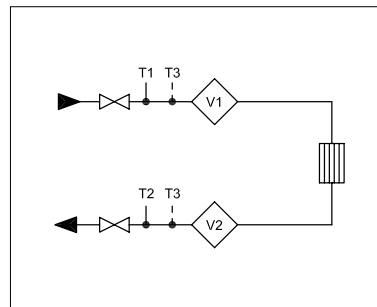

Example 1:
Closed thermal system
with 1 or 2 flow sensors

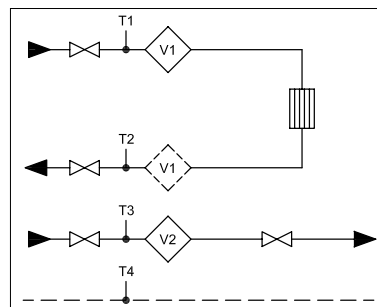

Example 2:
Closed thermal system
with 2 flow sensors

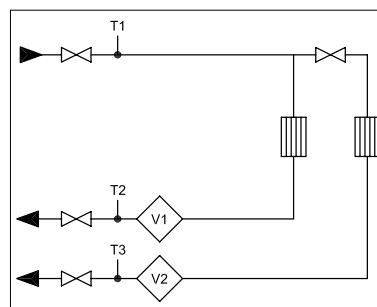

Example 3:
2 heat circuits with joint
flow

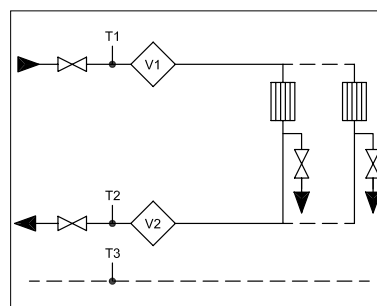

Example 4:
Open system with 2 flow
sensors

Calculator functions

Flow measurement

MULTICAL® 801 calculates current water flow according to two different principles depending on the connected flow sensor type:

- The flow indication of electronic flow meters is updated every 10 seconds.
- The flow indication of mechanical flow meters, typically with reed contact, is calculated on the basis of periodic time measurement and is updated with each volume pulse.

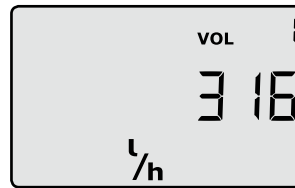

Power measurement

MULTICAL® 801 calculates current power on the basis of current water flow and the temperature difference measured in connection with the latest integration.

Current power is updated in the display simultaneously with the flow update.

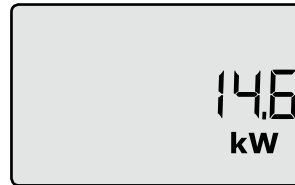

Min. and max. flow and power

MULTICAL® 801 registers minimum and maximum flow and power on a monthly as well as on a yearly basis. The registrations which appear from the display or can be read via data communication include max. and min. flow and power values, all with date indication.

All max. and min. values are calculated as largest and smallest average respectively of a number of current flow or power measurements. The average period used for all calculations is selected in the interval 1...1440 min.

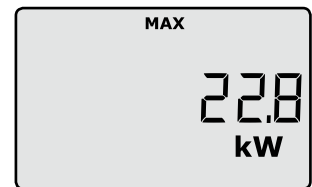
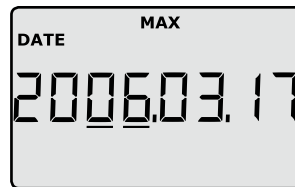

Temperature measurement

MULTICAL® 801 is available in different versions for either Pt100 or Pt500 sensors as well as in 2-wire and 4-wire versions.

The measuring circuit includes a high resolution analog/digital converter with a temperature range of 0.00°C...185.00°C.

In addition to current temperatures for the energy calculation average temperatures on a yearly and monthly basis can also be displayed.

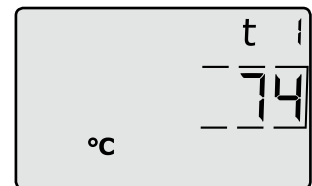

Display functions

MULTICAL® 801 is equipped with a clear LC display including 8 digits, units of measurement and information panel. In connection with energy and volume readings 7 or 8 digits and the units of measurement to match are used, whereas 8 digits are used when e.g. meter number is read.

As a starting point the display shows accumulated energy. When the push buttons are activated the display reacts immediately by calling other readings. The display automatically returns to accumulated energy reading 4 minutes after the latest activation of the push buttons.

The upper push button is used to switch between the primary readings. The consumers typically use the first primary readings in connection with self-reading for billing purposes.

The lower push button is used to show secondary information on the selected primary reading.

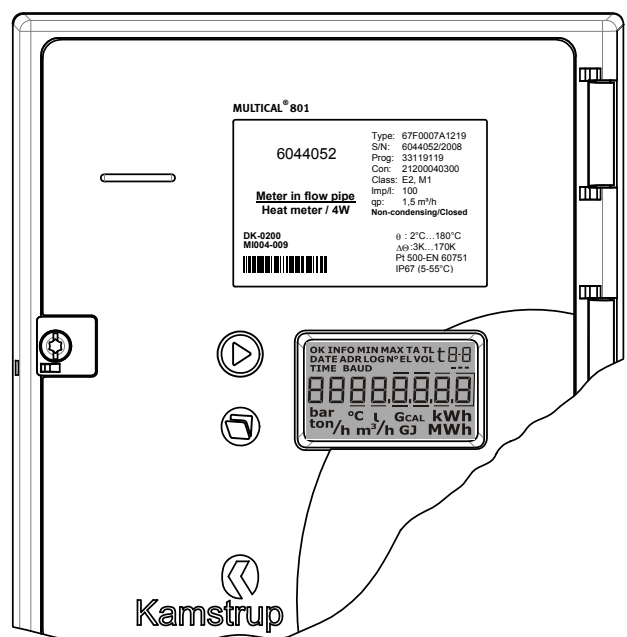

Calculator functions

Info codes

MULTICAL® 801 constantly monitors a number of important functions, e.g. power supply, temperature sensors and leakage alarms. Should a serious error occur in the measuring system or in the installation, a flashing “info” will appear in the display whilst the error exists. The “info” panel will automatically disappear when the error has been corrected.

An info event logger indicates how many times the info code has been changed.

The info logger stores the latest 50 changes, of which 36 can be displayed.



Standard

Info code	Description	Response time
00000	No irregularities	-
00001	The supply voltage has been interrupted	-
00008	Temperature sensor T1 outside measuring range	1...10 min.
00004	Temperature sensor T2 outside measuring range	1...10 min.
00032	Temperature sensor T3 outside measuring range	1...10 min.
00064	Leak in cold water system	24 hours
00256	Leak in heating system	24 hours
00512	Burst in heating system	120 sec.

ULTRAFLOW® X4 info (must be activated CCC=4XX)

Info code	Description	Response time
00016	Flow meter V1 communication error, signal too weak or wrong flow direction	After reset and 24 hours (at 00:00)
01024	Flow meter V2 communication error, signal too weak or wrong flow direction	After reset and 24 hours (at 00:00)
02048	Flow meter V1 wrong pulse figure	After reset and 24 hours (at 00:00)
00128	Flow meter V2 wrong pulse figure	After reset and 24 hours (at 00:00)
04096	Flow meter V1, signal too weak (air)	After reset and 24 hours (at 00:00)
08192	Flow meter V2, signal too weak (air)	After reset and 24 hours (at 00:00)
16384	Flow meter V1 wrong flow direction	After reset and 24 hours (at 00:00)
32768	Flow meter V2 wrong flow direction	After reset and 24 hours (at 00:00)

Calculator functions

Data loggers

MULTICAL® 801 contains a permanent memory (EEPROM), where the results of a number of various data loggers are stored. The meter contains the following data loggers which can be read on the display or via serial data:

Data logging interval	Data logging depth	Logged value
Yearly logger	15 years	Counter (as seen on the display)
Monthly logger	36 months	Counter (as seen on the display)
Daily logger	460 days	Consumption (increase)/day
Programmable data logger 1...1440 min.		Counter (as seen on the display)
Info logger	50 events	Info code and date

Leak surveillance

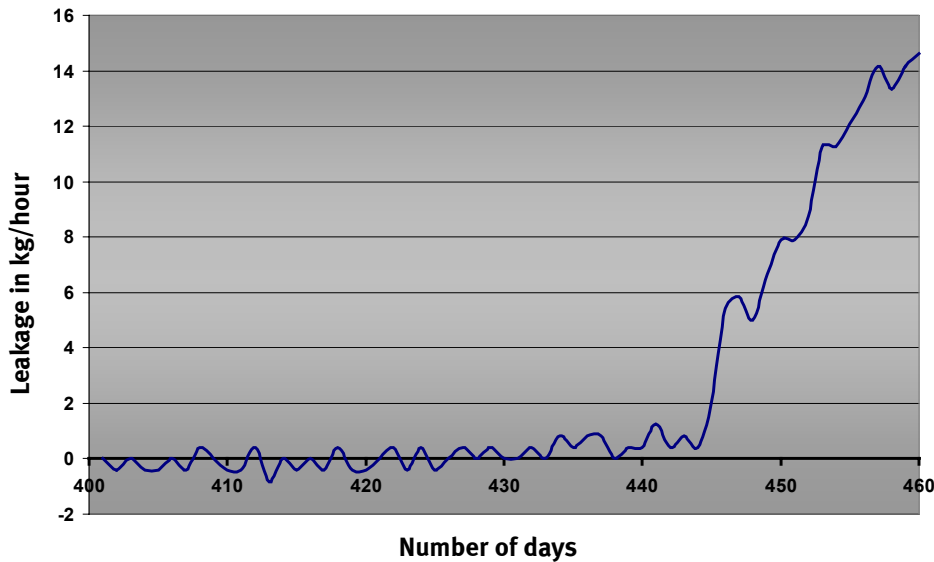

District heating systems

The leak surveillance system is primarily intended for direct connected district heating installations. The surveillance system consists of two water meters based on the ultrasonic principle, placed in flow and return pipe respectively, and of temperature sensors in both pipes. MULTICAL® 801 monitors the mass difference that may appear between flow and return pipe.

Cold-water systems

The pulse signal from the cold-water meter of the house can be connected to MULTICAL® 801. In this way it can monitor the cold-water consumption. A flushing toilet cistern, leaky heating coils in the water tanks or other leaks will cause that impulses from the cold-water meter are received 24 hours a day.

Calculator functions

Pulse outputs CE and CV

MULTICAL® 801 has pulse outputs for energy and volume pulses respectively. CE on terminals 16-17 releases one pulse per least significant digit of the energy count in the display and CV on terminals 18-19 releases one pulse per least significant digit of the volume count in the display.

If a higher resolution of pulse outputs is required, a CCC code with high resolution must be selected.

Pulse inputs VA and VB

MULTICAL® 801 has two pulse inputs, VA and VB, to collect and accumulate pulses remotely, e.g from cold-water meters and electricity meters. The pulse inputs are physically placed on "Module 1".

The pulse inputs VA and VB function independently of the other inputs/outputs.



Data connection [62-64]

MULTICAL® 801 has data connection on terminals 62-63-64. The data connection is passive and optoisolated, as shown in the block diagram to the right. Adaption to RS 232 level is possible via data cable type 66-99-106. Adaption to USB is possible via data cable 66-99-098.

The data connection uses the KMP protocol. Please contact Kamstrup for further details on the KMP protocol.

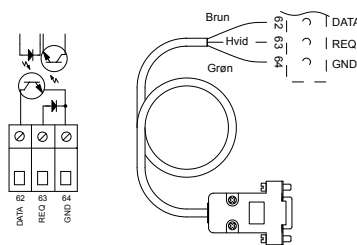

Voltage supply

MULTICAL® 801 is available with 230 VAC or 24 VAC supply voltage. Both types have battery backup, which secures clock and energy measurement during power failure.

Plug-in modules

Two plug-in modules, Module 1 and 2, can be added to MULTICAL® 801, in this way the meter can adapt to various applications and data reading methods.

Programming and verification

METERTOOL for MULTICAL® 801 is a Windows® -based software which includes all facilities for calculator programming. If the software is used together with VERIFICATION EQUIPMENT for MULTICAL® 801, the calculator can be tested and verified.

Tariff functions

MULTICAL® 801 has 2 extra registers TA2 and TA3 to accumulate energy parallelly to the main register based on a programmed tariff condition. No matter which tariff type you select the tariff registers will be displayed as TA2 and TA3.

The main register is always accumulated, irrespective of the selected tariff function, as it is considered the legal billing register. Tariff conditions TL2 and TL3 are monitored before each integration. If the tariff conditions are fulfilled, the consumed heat energy is accumulated in either TA2 or TA3, as well as the main register.

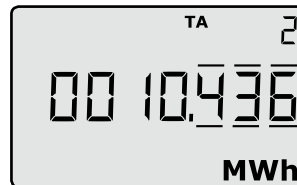

Cabinet design

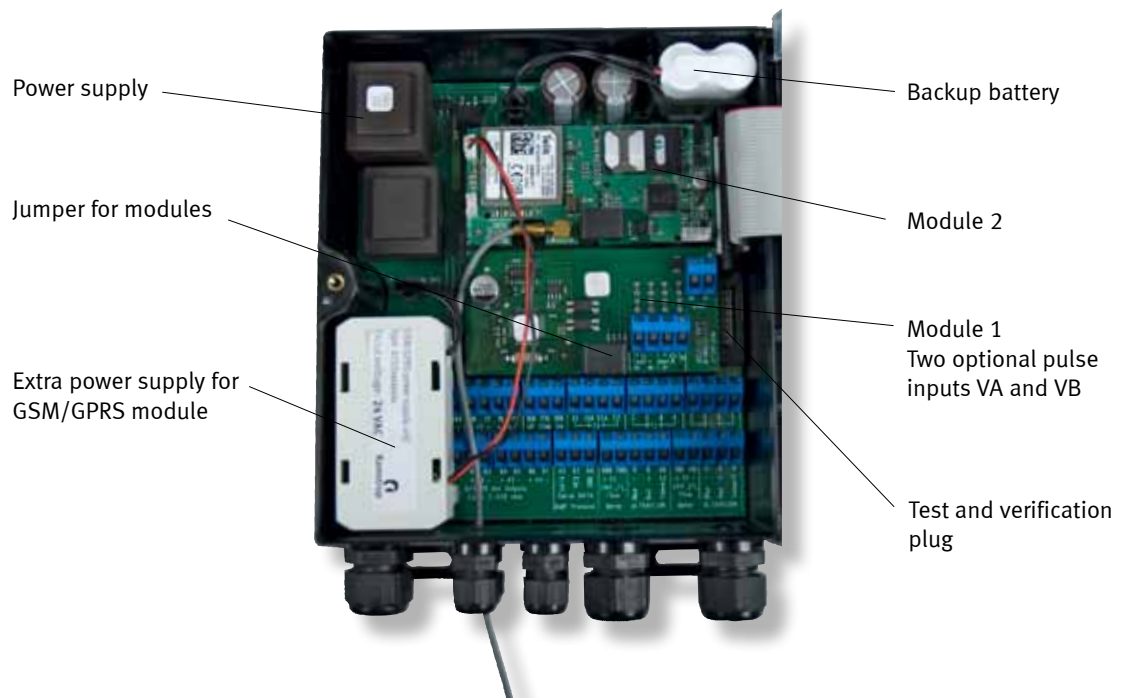

Approved meter data

Approval	DK-0200-MI004-009	Flow sensor types	
Standard	EN 1434:2007 and OIML R75:2002	– ULTRAFLOW®	
EU-directives		– Electronic meters with active and passive pulse output	
– MID (Measuring Instruments Directive)		– Mechanical meters with electronic pick-up	
– LVD (Low Voltage Directive)		– Mechanical meters with reed switch	
– EMC (Electromagnetic Compatibility Directive)			
Temperature range	θ: 2°C...180°C	Flow sensor sizes	
Differential range	Δθ: 3K...170K	– [kWh]	qp 0.6 m³/h...qp 15 m³/h
Accuracy	$E_c \pm(0.5 + \Delta\theta_{\min}/\Delta\theta)\%$	– [MWh]	qp 0.6 m³/h...qp 15000 m³/h
Temperature sensors		– [GJ]	qp 0.6 m³/h...qp 30000 m³/h
– Type 67-F and 67-K	Pt100 – EN 60 751, 4-wire connection	EN 1434 designation	Environmental class A and C
– Type 67-G and 67-L	Pt500 – EN 60 751, 4-wire connection	MID designation	
		– Mechanical environment Class M1	
		– Electromagnetic environment Class E1 and E2	
		– Non condensing, closed location (indoor installation), 5...55°C	

Electrical data

Calculator data

Typical accuracy	
– Calculator	$E_c \pm(0.15 + 2/\Delta\theta)\%$
– Sensor set	$E_T \pm(0.4 + 4/\Delta\theta)\%$
Display	LCD – 7 (8) digits with a digit height of 7.6 mm with back illumination
Resolution	9999.999 – 99999.99 – 999999.9 – 9999999 – 99999999
Energy units	MWh – kWh – GJ – Gcal
Data logger (Eeprom)	
– Standard	460 days, 36 months, 15 years, 50 info codes
– Standard	Programmable data logger with a logging depth of 1080 registers
Clock/calendar	
– Standard	Clock, calendar, leap-year compensation, target date
– Standard	Real time clock with battery back-up
– Standard	Battery backup of energy measurement incl. ULTRAFLOW®
Data communication	
– Standard	KMP protocol with CRC16 used for optical communication and for base modules

Power in temperature sensors	< 10 μW RMS
Mains supply	
– 230 VAC	+15/-30%, 50/60 Hz (all types)
– 24 VAC	±50%, 50/60 Hz (Type 67-F/G without analogue outputs)
– 24 VAC	±25%, 50/60 Hz (Type 67-K/L with analogue outputs)
Insulation voltage	4 kV
Power supply	< 3W without analogue outputs < 9W with analogue outputs
Power consumption	Max. 50 mA/230 VAC Max. 450 mA/24 VAC
Battery backup	3.65 VDC, 2 pcs A-celle lithium (Type No. 66-99-619)
Replacement interval	10 years at normal operation (with supply)
Backup period	1 year (without supply) The replacement interval is reduced at high ambient temperature.
EMC data	Meets EN 1434 Class A and C (MID Class E1 and E2).

Temperature measurement		T1	T2	T3	T4
67-F and 67-K	Measuring range	0.00...185.00°C	0.00...185.00°C	0.00...185.00°C	N/A
4-W Pt100	Preset range	0.01...180.00°C	0.01...180.00°C	0.01...180.00°C	0.01...180.00°C
67-G and 67-L	Measuring range	0.00...185.00°C	0.00...185.00°C	0.00...185.00°C	N/A
4-W Pt500	Preset range	0.01...180.00°C	0.01...180.00°C	0.01...180.00°C	0.01...180.00°C

Max. cable length	Pt100, 2-wire	Pt500, 2-wire	Pt500, 4-wire
	2 x 0.25 mm²: 2.5 m	2 x 0.25 mm²: 10 m	4 x 0.25 mm²: 100 m
	2 x 0.50 mm²: 5 m	2 x 0.50 mm²: 20 m	

Electrical data

Flow measuring V1 and V2	ULTRAFLOW® V1: 9-10-11 and V2: 9-69-11	Reed switches V1: 10-11 and V2: 69-11	24 V active pulses V1: 10B-11B and V2: 69B-79B
EN 1434 pulse class	IC	IB	(IA)
Pulse input	680 kΩ pull-up to 3.6 V	680 kΩ pull-up to 3.6 V	12 mA at 24 V
Pulse ON	< 0.4 V for > 0.5 msec.	< 0.4 V for > 50 msec.	< 4 V for > 0.5 msec.
Pulse OFF	> 2.5 V for > 10 msec.	> 2.5 V for > 50 msec.	> 12 V for > 10 msec.
Pulse frequency	< 128 Hz	< 1 Hz	< 128 Hz
Integration frequency	< 1 Hz	< 1 Hz	< 1 Hz
Electrical isolation	No	No	2 kV
Max. cable length	10 m	25 m	100 m

Pulse inputs VA and VB VA: 65-66 and VB: 67-68	Water meter connection FF(VA) and GG(VB) = 01...40	Electricity meter connection FF(VA) and GG(VB) = 50...60
Pulse input	680 kΩ pull-up to 3.6 V	680 kΩ pull-up to 3.6 V
Pulse ON	< 0.4 V for > 20 msec.	< 0.4 V for > 20 msec.
Pulse OFF	> 2.5 V for > 100 msec.	> 2.5 V for > 100 msec.
Pulse frequency	< 1 Hz	< 3 Hz
Electrical isolation	No	No
Max. cable length	25 m	25 m
Requirements to external contact	Leakage current at function open < 1 μA	

Pulse outputs CE and CV Energy (16-17) Volume (18-19)	
Type	Open collector (OB)
Pulse length	Programmable 32 msec. or 100 msec. via METERTOOL
External voltage	5...30 VDC
Current	1...10 mA
Residual voltage	$U_{CE} \approx 1 \text{ V}$ at 10 mA
Electrical isolation	2 kV
Max. cable length	25 m

Mechanical data

Environmental class	Meets EN 1434 Class A and C	Weight	1.4 kg excluding sensors and flow sensor
Ambient temperature	5...55°C non condensing, closed location (indoor installation)	Connection cables	6 pcs ø3...6 mm and 3 pcs ø 4...8 mm
Protection class	IP67		
Storage temperature	-20...60°C (drained flow meter)		

Materials

Top cover	PC	Sealing cover, bottom	PC
Base unit	PP + 10%GF	Prism behind display	PMMA
Sealing cover, top	ABS		

Order specifications

MULTICAL® 801		Type 67-	<input type="checkbox"/>	<input type="checkbox"/>	<input type="checkbox"/>	<input type="checkbox"/>	<input type="checkbox"/>	<input type="checkbox"/>	<input type="checkbox"/>	<input type="checkbox"/>	<input type="checkbox"/>
Sensor connection											
Pt100 – 4-wire (T1-T2-T3)	no analogue outputs	F									
Pt500 – 4-wire (T1-T2-T3)	no analogue outputs	G									
Pt100 – 4-wire (T1-T2-T3)	4 analogue outputs	K									
Pt500 – 4-wire (T1-T2-T3)	4 analogue outputs	L									
Module 2 (VA and VB are not available at module place 2)											
No module		0									
M-Bus		V									
RadioRouter **)		W									
LonWorks, FTT-10A		Y									
GSM/GPRS module **)		Z									
Module 1 (VA and VB are available at module place 1)											
No module					00						
M-Bus + pulse inputs					20						
RadioRouter + pulse inputs **)					21						
Data logger + 4-20 mA inputs + pulse inputs					22						
LonWorks, FTT-10A + pulse inputs					24						
Supply											
230 VAC						7					
24 VAC						8					
Pt500 sensor set (2-wire sensors)											
No sensor set							0				
Pocket sensor set w/1.5 m cable							A				
Pocket sensor set w/3.0 m cable							B				
Pocket sensor set w/5 m cable							C				
Pocket sensor set w/10 m cable							D				
Short direct sensor set w/1.5 m cable							F				
Short direct sensor set w/3.0 m cable							G				
3 pocket sensors in sets w/1.5 m cable							L				
3 short direct sensors in sets w/1.5 m cable							Q3				
Flow sensor/pick-up unit											
*) Supplied w/1 ULTRAFLOW®	(Please specify type)						1				
*) Supplied w/2 (identical) ULTRAFLOW®	(Please specify type)						2				
Prepared for 1 ULTRAFLOW®	(Please specify type)						7				
Prepared for 2 (identical) ULTRAFLOW®	(Please specify type)						8				
Prepared for meters w/electronic pulse output							K				
Prepared for meters w/reed switch output (both V1 and V2)							L				
Prepared for meters w/24 V active pulses							M				
Meter type											
Heat meter								2			
Heat meter, closed systems (MID)								4			
Cooling meter								5			
Heat/cooling meter								6			
Volume meter, hot water								7			
Volume meter, cooling water								8			
Energy meter, open systems								9			
Country code (language on label etc.)											XX

- *) ULTRAFLOW® is delivered in a separate box which is strapped together with the MULTICAL® 801 carton.
The cable between MULTICAL® 801 and ULTRAFLOW® is not connected on delivery.
- **) GSM module and RF module are NOT combinable in the same meter.

Accessories

Type No.	Description
66-99-098	Data cable w/USB plug
66-99-099	Infrared optical reading head w/USB plug
66-99-102	Infrared optical reading head RS232 w/D-sub 9F
66-99-106	Data cable RS232, D-sub 9F
66-99-136	Infrared optical reading head for Kamstrup/EVL w/RS232 w/D-sub 9F
66-99-144	Infrared optical reading head for Kamstrup/EVL w/USB plug
66-99-370	Verification unit, Pt100 (used with METERTOOL)
66-99-371	Verification unit, Pt500 (used with METERTOOL)
66-99-619	Battery backup (2xA cell lithium battery)
66-99-278	Short circuit pen (for total reset and total programming)
66-99-209	Short circuit jumper (for use with 2-wire temperature sensors)
16-40-080	Jumper for modules
65-56-4x-xxx	Temperature sensor set with connecting head (2/4 wired)
5920-177	Cable gland wrench 15 mm
5920-178	Cable gland wrench 19 mm
66-99-707	METERTOOL for MULTICAL® 801
66-99-708	METERTOOL LogView for MULTICAL® 801

Please contact Kamstrup A/S for questions concerning further accessories.

Tolerance band

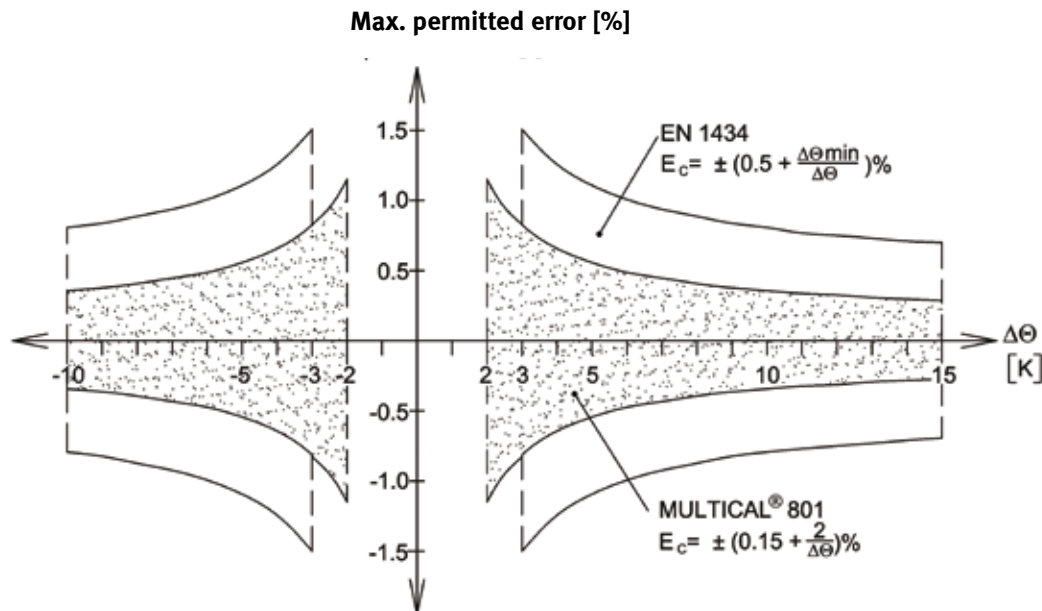

The above diagram shows the typical tolerance band of MULTICAL® 801 compared to the tolerance requirements of EN 1434.

Dimensional sketches

Front dimensions of MULTICAL® 801

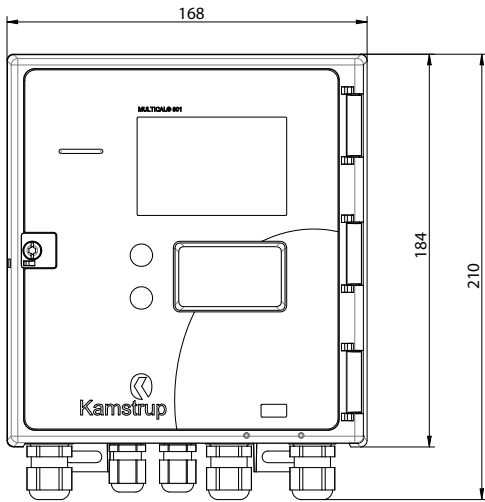

Mounting dimensions of MULTICAL® 801

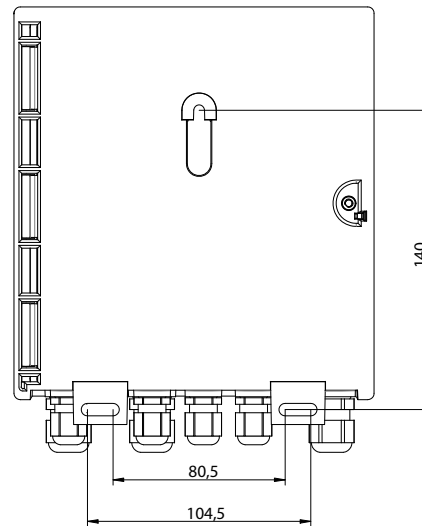

Wall-mounted MULTICAL® 801 seen from the side MULTICAL® 801 cable connections

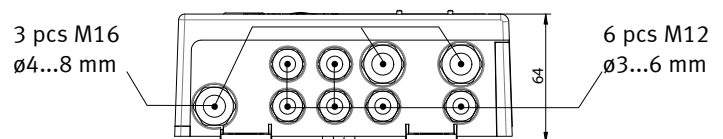
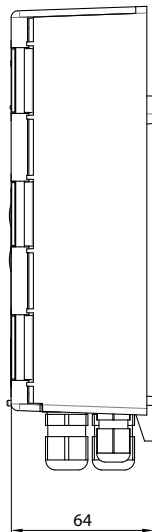

All dimensions in [mm]